



Packaging machines



User manual

www.audion.com

Continuous sealer

D541

D541 ENG Rev.01

All rights reserved.

No part of this publication may be reproduced and/or published by means of print, photocopy, or in any other way, without prior written permission from Audion Elektro BV.

Audion Elektro BV reserves the right to modify the machine and/or change the operating manual without prior notice.

Audion Elektro BV is not liable for any damage caused by specifications deviating from the standard version.

Although this operating manual was compiled with the utmost care, Audion Elektro BV does not accept any liability for any mistakes it may contain and/or the consequences of any incorrect interpretation of its contents.

Audion Elektro BV is not liable for any damage or problems resulting from the use of parts other than original parts. If this operating manual does not provide instructions for certain repairs, settings or maintenance, please contact your dealer or Audion Elektro BV.



Please read this operating manual carefully before using the sealer or carrying out maintenance on it.

The sealer is part of the Audion product range. We also provide:

- Impulse sealers.
- Heat sealers.
- Continuous sealers.
- Vacuum sealers.
- Vacuum chambers.
- Crimping machines.
- Validatable sealers.
- Form, fill and seal machines.

Since its inception in 1947, Audion has gained a lot of experience and expertise with a wide variety of sealing and packaging machines. Our solutions for packaging problems are unique. Our many years of experience together with our modern production, assembly and testing methods ensure that our packaging machines meet the highest quality standards. We can also customise the machines according to your specific requirements.

Audion is the right supplier for a packaging machine that is geared to your requirements.

Contents

1	Introduction	6
1.1	Manufacturer	6
1.2	Machine type plate	6
1.3	Warranty conditions and liability	7
2	Safety	8
2.1	Symbols used in this manual	8
2.2	User	9
2.2.1	Operating personnel	9
2.2.2	Maintenance personnel	9
2.3	Safety instructions	10
2.3.1	General safety instructions	10
2.3.2	What to do in case of fire	11
2.3.3	Use for special applications	12
2.4	Safety provisions	12
3	Installation	13
3.1	Unpacking the sealer	13
3.2	Fixing the adhesive feet	13
3.3	Connecting the sealer	14
4	Description	
	Continuous sealer¹⁵	
4.1	Function	15
4.2	Overview of the Continuous sealer	16
4.3	Control panel	17
4.3.1	Coolrun mode	17
5	Operation	18
5.1	Switching on the sealer	18
5.1.1	Setting the sealing temperature	18
5.1.2	Adjusting the film guide	19
5.2	Sealing	19
5.2.1	Sealing of large bags	19
5.2.2	Sealing of smaller bags	19
5.3	Stopping the sealer (STANDBY mode)	20
5.4	Changing the operating settings	21
5.4.1	Resetting the default operating settings	23
6	Troubleshooting	24

7	Maintenance	26
7.1	Maintenance schedule	27
7.1.1	Weekly maintenance	27
7.1.2	Monthly maintenance	27
7.1.3	Annual maintenance	27
7.2	Replacing the PTFE fibreglass belts	28
7.3	Replacing the fuse	30
8	Disposing of the machine	31
8.1	Directive 2002/96/EC	31
8.2	Correct disposal for reuse	31
Bijlage 1	Technical information	32
B1.1	Dimensional drawing	32
B1.2	Technical information	33
Bijlage 2	Electrical Diagram	35
Bijlage 3	Spare parts	37
B3.1	Wear parts	37
B3.2	Service parts	38
B3.3	Exploded view	39
Bijlage 4	Log	40
B4.1	Maintenance log	41
Bijlage 5	EC declaration	42

1 Introduction

1.1 Manufacturer

The Continuous sealer was manufactured by:

Audion Elektro BV	
Hogeweyselaan 235	
1382 JL Weesp	
The Netherlands	
Telephone:	+ 31 (0)294 491717
Fax:	+ 31 (0)294 491755
Email:	holland@audion.nl
Web:	www.audion.com

1.2 Machine type plate

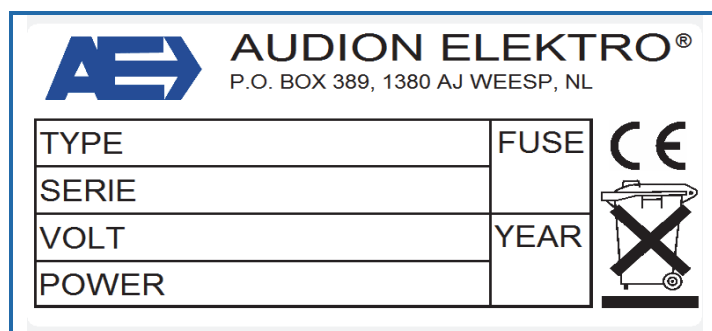

Figure 1-1: Machine type plate of the Continuous sealer

The sealer has an EC mark. This means that the sealer meets the fundamental health and safety requirements of the European Communities.

1.3 Warranty conditions and liability

Subject to the limitations stated below, we provide a 12-month warranty for the products we deliver. This warranty is limited to manufacturing defects and therefore does not cover any malfunctions caused by any form of wear, or any part of the delivered product that is subject to wear.

- The warranty we provide for parts or accessories purchased from third parties is limited to the warranty the third-party provides to us.
- The warranty is void if the other party and/or any third parties engaged by them use the product in a way that it is not intended for.
- The warranty is also void if the other party and/or any third parties engaged by them carries out work and/or modifications on the delivered product.
- Any parts we replace in order to meet our warranty obligations become our property.
- Should the other party not meet obligations resulting from the agreement entered into between the parties in whole or in part or in a timely manner, we are not obliged to provide warranty for as long as that situation continues.

We exclude all liability to the extent that the liability is not regulated by law. Our liability will never exceed the total amount of the order in question.

Subject to the generally applicable legal rules of public order and good faith, we are not obliged to pay compensation to the other party or any third party for damages of any nature whatsoever, incurred directly or indirectly, including trading loss, damage to movable or immovable property or persons.

In any case, we are not liable for any damage resulting from or caused by using the delivered product or its unsuitability for the purpose for which the other party purchased it.

2 Safety

2.1 Symbols used in this manual

The following symbols are used in this user manual:



A tip on how a task can be carried out more efficiently.



Instructions for carrying out a task in the correct manner.



Danger of injury to the user or damage to the sealer if the instructions are not observed.

2.2 User



The sealer should only be operated by authorised personnel.



Improper use of the sealer may lead to serious personal injury and considerable material damage.



Keep bystanders at a distance. Do NOT allow unauthorised personnel to operate the sealer.

2.2.1 Operating personnel

The company using the machine has organized a training to inform its operating personnel of the potential risks of unskilled behaviour while carrying out their tasks.



Installation, maintenance and repair require specialised knowledge, which is why these tasks should only be performed by maintenance personnel.



Observe the safety instructions in this user manual. Failure to observe the safety instructions may cause unacceptable risks.

The operating personnel must be familiar with all chapters of this user manual with the exception of 'Installation' and 'Maintenance'. Always observe the following safety instructions before using the sealer or carrying out any maintenance work.

2.2.2 Maintenance personnel

This personnel's professional training, knowledge and experience, and knowledge of the manufacturer's terms enable them to carry out the assigned work and immediately recognize any risks that may arise.



Observe the safety instructions in this user manual. Failure to observe the safety instructions may cause unacceptable risks.

Maintenance personnel must be familiar with all chapters of this user manual. Always observe the following safety instructions before using the sealer or carrying out any maintenance work on it.

2.3 Safety instructions

The sealer meets the fundamental health and safety requirements of the European Community. This means that the sealer can be operated and maintained safely if all safety instructions are carefully observed. However, improper or careless use can create dangerous situations.



Observe the safety instructions in this user manual. Always remain alert to dangerous situations and avoid any improper or careless use.

2.3.1 General safety instructions

Observe the following general safety instructions:

- Tie back long hair.
- Do not wear loose clothing or jewellery.



- Always wear the personal protective equipment (PPE) prescribed by the company, such as safety shoes, gloves, and goggles.



Use the PPE required on the shop floor, such as safety shoes, gloves and goggles and/or hearing protection, in particular when carrying out maintenance work.

- Check the operation of the sealer every day.
- Keep your hands away from dangerous parts of the sealer.
- Always leave protective covers in place during production.
- Never bypass or deactivate any safety provisions.
- The sealer should never be operated or maintained by people who are under the influence of alcohol, medication and/or drugs.
- Only use sealable material that is suitable for the sealer.
- The user is obliged to observe the commonly applicable hygienic measures.
- If you are not sure whether the sealer is working properly, switch it off immediately and consult the maintenance personnel.
- Both the user and the sealer must be supervised while the sealer is in use.

- Do not switch the sealer back on until the malfunction has been repaired.
- Should any liquid or foreign object enter the machine, switch off the sealer and immediately remove the plug from the wallsocket and have the sealer checked by maintenance personnel before using it again.
- Should an unusual event occur, such as the development of smoke, remove the plug from the socket immediately and have the sealer checked by maintenance personnel before using it again.
- Remove the plug from the socket before carrying out any maintenance work.
- Never open the sealer's housing while it is connected to the mains power.
- Do not use any water, abrasive cleaning agents, chemical solvents or other liquids when cleaning the sealer.

2.3.2 What to do in case of fire



NEVER use water to extinguish a fire. This may result in life-threatening situations because the sealer may be live.

Should the sealer catch fire, never use water to extinguish the fire. Because the sealer is live, this may result in life-threatening situations. A fire extinguisher must be within reach when the sealer is in use. The following types of fire extinguishers are suitable to extinguish a burning sealer:

- Powder extinguisher.
- Foam extinguisher.

2.3.3 Use for special applications



If the machine is used in a special environment, the company using the machine must ensure that any instructions specific to that environment are observed.

- If the machine is used in a medically sterile environment or clean room, the company using the machine must ensure that any instructions specific to this environment are observed.
- If the machine is used for the packaging of medical instruments, the company using the machine must ensure that any instructions specific to this environment are observed.
- If the machine is used for the packaging of food, the company using the machine must ensure that any instructions specific to this environment are observed.

2.4 Safety provisions

The sealer has the following safety provisions:

1. Safety covers.
 - Electrical and mechanical parts in the housing are protected.
2. Metal parts are earthed.
 - No dangerous voltage can develop between (external) metal parts and the earth.
3. Fuse in 230 V circuit.
 - If the voltage gets too high, the fuse will blow, cutting off the power supply.

3 Installation

3.1 Unpacking the sealer

Check the following when unpacking the sealer:

1. **Are** all parts and accessories present?

- D541 sealer.
- Power cord.
- Set of adhesive feet.
- Instructions.



The sealer is packaged in environmentally friendly material that can be disposed of as ordinary household waste.



Keep the box and the packaging material so the sealer can be safely transported, should such be necessary.

3.2 Fixing the adhesive feet

1. **Stick** the adhesive feet to the bottom of the sealer



The adhesive feet are important for a good air flow to be realised through the grate.



If the adhesive feet are not used, the surface on which the sealer is placed may be damaged.

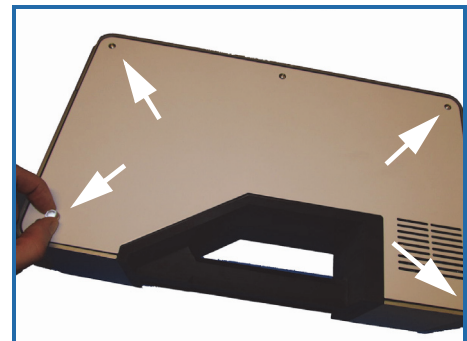

3.3 Connecting the sealer

1. **Connect** the female plug of the power cord to the sealer.

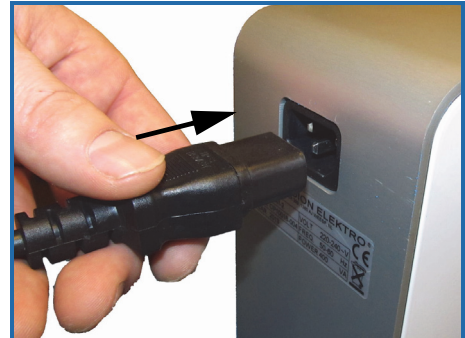

2. **Put** the plug in the socket.

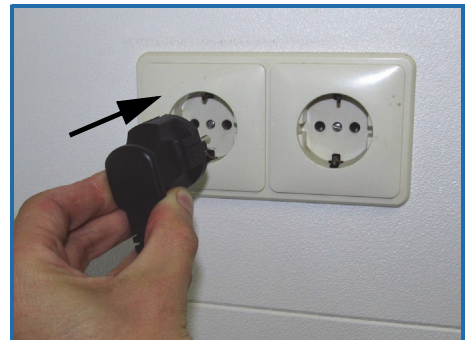

4 Description

Continuous sealer

4.1 Function

The D541 is a Continuous sealer for the packaging of a wide variety of products in small series. The products are packaged in ready-to-use bags and subsequently sealed. The sealer is suitable for ready-to-use bags made of polyethylene (PE), polypropylene (PP), and aluminium laminates, with a thickness of between $2 \times 20 \mu\text{m}$ and $2 \times 120 \mu\text{m}$.



Do not use the Continuous sealer for any other applications.

The sealer is not suitable for the following applications:

- Use in an explosive environment.
- Use in a clean room environment.
- Use in a medical environment.
- Packaging of pharmaceutical and therapeutic products.
- Packaging of toxic, corrosive or irritating substances.
- Packaging of explosive materials.
- Packaging of toxic, asphyxiant or irritating gases.
- Packaging of (hazardous) dusty products.
- Packaging of liquids.

4.2 Overview of the Continuous sealer



Figure 4-1: Overview of the Continuous sealer

1. Housing
2. Handle
3. Control panel
4. Infeed guide

The sealer consists of a housing that contains electrical components. The handle is located on the top of the housing. It is used to hold the sealer while large bags are being sealed. The sealer may also be placed on its side, for example on a table. In that case, the sealer is not held in the hand; ideal for sealing small bags.

4.3 Control panel

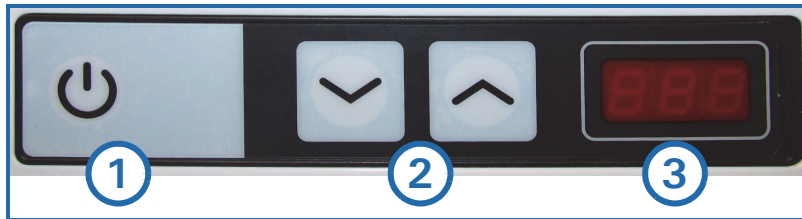

Figure 4-2: Control panel

- | | |
|---------------|--|
| 1. Start/stop | Press and hold for at least 1 second to start or stop the sealer.
When the sealer is switched on, the display shows the actual sealing temperature.
When the actual sealing temperature upon switching off is over 80°C, the sealer will first switch to Coolrun mode. |
| 2. Up/down | Press to increase or reduce the temperature setting. |
| 3. Display | Shows the actual sealing temperature. While making changes, the set value is displayed (and the value in the display is followed by a point). |

4.3.1 Coolrun mode

The coolrun mode prevents burning of the PTFE fibreglass belts. After the machine has been stopped, the heater is switched off; however, the blower and the motor will continue to run. When the sealing temperature has dropped to below 80°C, the sealer is switched to stand-by mode and the blower and the motor will also be switched off.

5 Operation



If necessary, put the plug in the socket.



The seal bar gets hot during use. Touching it can result in serious burns.

5.1 Switching on the sealer

Switch on the sealer as follows:

1. Press the START/STOP button for 1 sec.



If necessary, put the plug in the socket.



During the start-up, the operating settings are visible in the display. To change these settings, please refer to section 5.4.

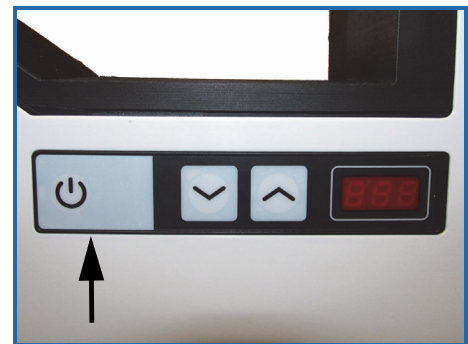

5.1.1 Setting the sealing temperature

The sealing temperature is set as follows:

1. Press the ARROW keys to increase or reduce the sealing temperature.



The guideline value for the sealing temperature is 100°C.



When the actual sealing temperature is within +/- 5°C of the set value, the temperature indicator will stop blinking.



5.1.2 Adjusting the film guide

The film guide is adjusted as follows:

1. **Loosen** the lock screw a few turns.
2. **Adjust** the film guide to the desired position.



The seal should be made at least 5 mm from the top of the bag.

3. **Tighten** the lock screw again.

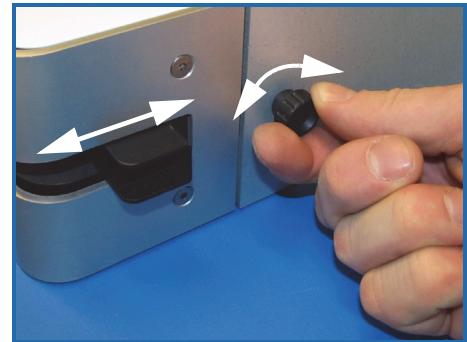

5.2 Sealing

5.2.1 Sealing of large bags

A product is sealed as follows:

1. **Take** the sealer in your hand.
2. **Guide** the bag to be sealed into the infeed guide.
3. **Move** the sealer across the bag to be sealed.



5.2.2 Sealing of smaller bags

A product is sealed as follows:

1. **Place** the sealer on a stable surface.
2. **Guide** the bag to be sealed into the infeed guide.



5.3 Stopping the sealer (STANDBY mode)

After use, stop the sealer as follows to put it in STANDBY mode:

1. Press the START/STOP button for 1 sec.



The sealer will now switch to STANDBY mode; the display will show a point in the bottom right-hand corner of the display.

When the sealing temperature is over 80°C, the sealer will first switch to COOLRUN mode. The heating is switched off and the blower and the motor will continue to run until the sealing temperature has dropped to below 80°C. The display will alternate between show "c-r" and the "actual temperature". After that, the sealer is automatically switched to STANDBY mode.



When the START/STOP button is pressed for longer than 3 seconds, the sealer will immediately switch to STANDBY mode, even if the sealing temperature is higher than 80°C. Use this way of switching off only if absolutely necessary. It may cause the PTFE fibreglass belts to burn sooner.



If the sealer is not going to be used for a longer period of time, it is better to switch it off completely by removing the plug from the socket.

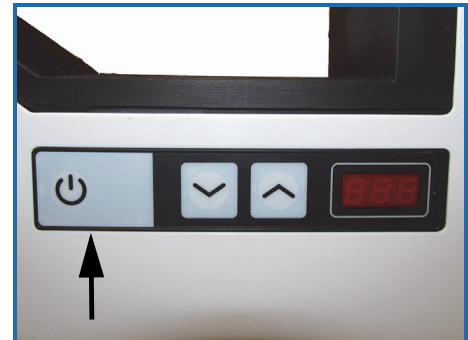

5.4 Changing the operating settings

The following settings can be changed:

Setting	Value	Description
Heater	H.01	The heater is on when the motor is running.
	H.02	The heater is off when the motor is running.
Maximum sealing temperature.	L.10, L11, ..., L20	The maximum sealing temperature to be set. 100 °C, 110 °C, ..., 200 °C
Blower	F.01	The blower is on when the motor is running.
	F.02	The blower is off when the motor is running.
Temperature offset	S.-20 through S.20	The sealing-temperature regulation makes use of a -20% through +20% offset compared to the sealing temperature that has been set.
Hour counter	Co	When the START/STOP button is pressed down during max. 1 second, the number of hours of operation are displayed. If the number of hours is higher than 3 digits, the display will move 1 position to the left every 0.5 seconds. After 1 second, the display once again shows Co.

Change the operating settings as follows:

1. During start-up, while the operating settings are shown in the display, **simultaneously press** the START/STOP button and the V ARROW button until USE appears in the display.



The two buttons have to be pressed during start-up, after the operating settings are shown in the display.

2. Select the setting to be changed by pressing the START/STOP button until it is shown in the display.

3. Change the setting by pressing the ARROW keys.

4. Save the changes by pressing the START/STOP button for 3 seconds.



The changed operating settings are saved and the sealer is restarted.

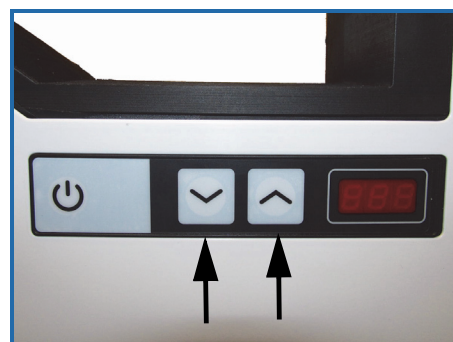
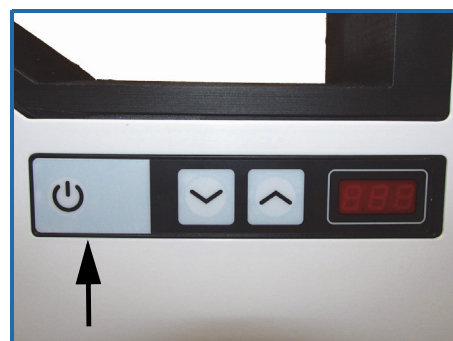
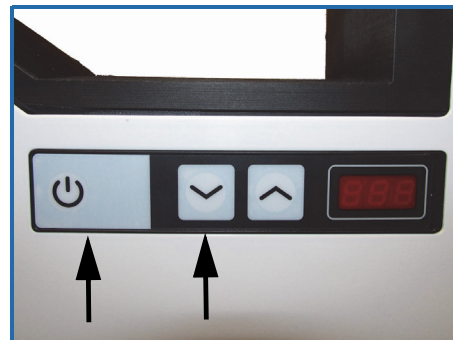

5.4.1 Resetting the default operating settings

Reset the operating settings to the default settings as follows:

1. During start-up, while the operating settings are shown in the display, **press** the START/STOP button until PRG appears in the display.



The START button has to be pressed during start-up, after the operating settings are shown in the display.

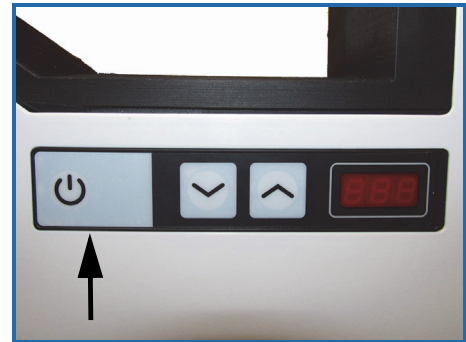

2. **Press** the ARROW keys until YES appears in the display.

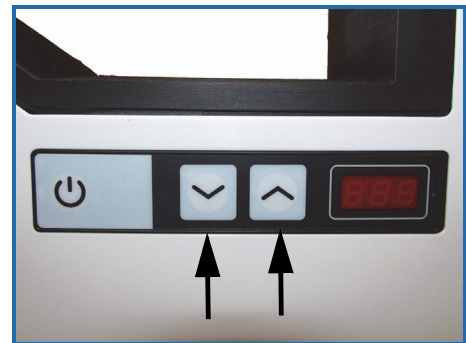

3. Save the changes by pressing the START/STOP button for 3 seconds.



The sealer is restarted and the operating settings have been reset to the default settings: H.01, L.20, F.01 and S.00.



6 Troubleshooting



Troubleshooting may only be performed by authorised maintenance personnel.



In the event of a malfunction, always pull the plug from the socket before attempting to solve the problem.



If the problem cannot be solved using the below troubleshooting table, please contact your dealer or Audion.

Problem	Cause	Solution
The sealer will not switch on.	The plug is not, or not properly, connected to the socket.	Put the plug properly in the socket.
	The power supply is out of order.	Check the power supply.
	The fuse has blown.	Replace the fuse. (see section 7.3)
	Internal malfunction.	Contact your dealer or Audion.
The sealer is not transporting the bags properly.	The PTFE glass-fibre belts are defective.	Check the PTFE glass-fibre belts and replace if necessary. (see section 7.2)
	The motor has been switched off.	Check the operating settings and switch on the motor if necessary. (see section 5.4)
	Internal malfunction.	Contact your dealer or Audion.
The sealer is not heating up.	The sealing temperature has been set too low.	Check the sealing temperature setting and increase if necessary. (see section 5.1.1)
	The heater has been switched off.	Check the operating settings and switch on the heater if necessary. (see section 5.4)
	Internal malfunction.	Contact your dealer or Audion.

Problem	Cause	Solution
The blower is not running.	The blower has been switched off.	Check the operating settings and switch on the blower if necessary. (see section 5.4)
	Internal malfunction.	Contact your dealer or Audion.
Error code E01	Malfunction temperature sensor (PT100), actual sealing temperature is too high.	Contact your dealer or Audion.
Error code E02	Malfunction temperature sensor (PT100), actual sealing temperature is too low.	Contact your dealer or Audion.

7 Maintenance



Maintenance should only be performed by authorised maintenance personnel.



Always remove the plug from the socket before carrying out any maintenance work.



Do not use any water, abrasive cleaning agents, chemical solvents or other liquids when cleaning the sealer.



The maintenance schedule is based on normal use. The frequency of maintenance must be increased if the machine is used intensively or under extreme conditions.



Always keep a log of all maintenance work. An example is given in Appendix 4 - 'Log'.

7.1 Maintenance schedule

7.1.1 Weekly maintenance



Weekly maintenance should be carried out by the operating personnel (see chapter 2 - 'Safety').

Part	Work
Sealer	Clean the sealer with a damp cloth and mild soap (for example, all-purpose cleaner).

7.1.2 Monthly maintenance



Monthly maintenance should only be performed by authorised maintenance personnel (see chapter 2 - 'Safety').

Part	Work
PTFE fibreglass belts	Check the condition of the PTFE fibreglass belts. Replace it if necessary. (see section 7.2 - 'Replacing the PTFE fibreglass belts')

7.1.3 Annual maintenance



Annual maintenance should only be performed by authorised maintenance personnel (see the preface).

Part	Work
Earth system	Check the earth according to NEN 3140 or EN 50110-1.

7.2 Replacing the PTFE fibreglass belts

Replace the PTFE fibreglass belts as follows:

1. **Remove** the plug from the socket.



Never carry out maintenance on the Continuous sealer while it is live.



2. **Loosen** the four screws at the side of the sealer.
3. **Remove** the cover.



Warning! The heating blocks can still be hot, even if the sealer has been switched off for a while.



4. **Push** the left-hand side tension roller inward.
5. **Remove** the PTFE glass-fibre belts from the right-hand side tension roller.



6. **Place** the PTFE glass-fibre belt onto the tension roller.

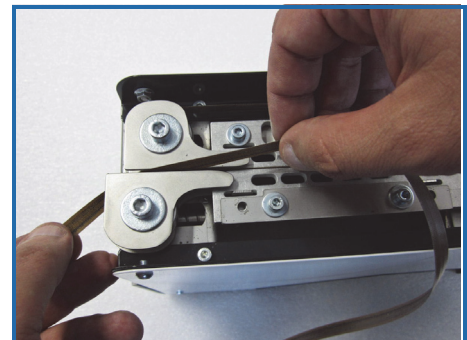

7. **Push** the bottom cooling plate downward slightly.
8. **Slide** the PTFE glass-fibre belt in-between the cooling plates.

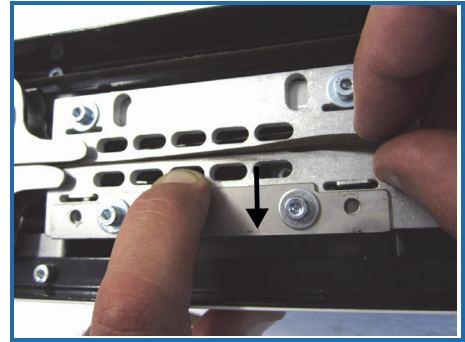

9. **Push** the bottom heating element downward slightly.
10. **Slide** the PTFE glass-fibre belt in-between the heating elements.

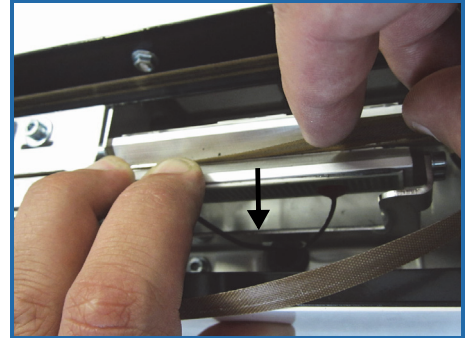

11. **Push** the tension roller (left) inward.
12. **Place** the PTFE glass-fibre belt around the guide roller on the right.
13. **Release** the tension roller and allow it to gently spring back into place.

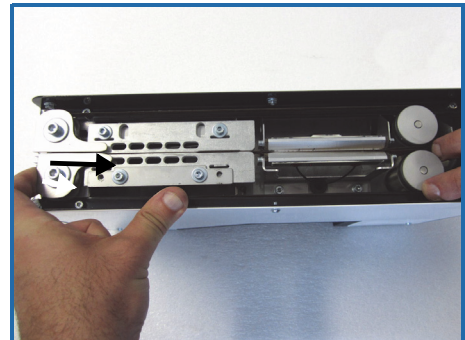

Always check whether the PTFE glass-fibre belts run smoothly across the rollers.

14. **Place** the cover back.
15. **Tighten** the four bolts again.

7.3 Replacing the fuse

Replace the fuse as follows:

1. **Remove** the plug from the socket.



Never carry out maintenance on the sealer while it is live.



2. **Loosen** the five screws that hold the back plate in place.
3. **Remove** the back plate from the sealer.

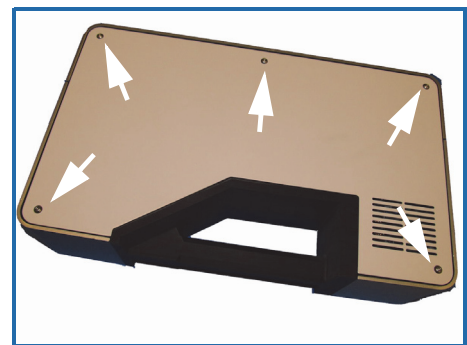

4. **Remove** the protective cover from the fuse holder.
5. **Remove** the old fuse and replace it with a new one of the same type.



See Appendix 1.2 - 'Technical information' for the type of fuse. Never use a different type of fuse!



It is recommended to replace both fuses at the same time, even if only one of them is defective.

6. **Place** the protective cover back.
7. **Place** the back plate back into the housing.
8. **Tighten** the five screws again.

8 Disposing of the machine



Correct disposal of the machines and equipment helps protect the environment and public health.

8.1 Directive 2002/96/EC

According to the European Directive 2002/96/EC on waste electrical and electronic equipment (WEEE), the adjacent pictogram indicates that the machine or the piece of equipment to which it has been applied is to be collected separately from other waste and may not be disposed of together with other waste.

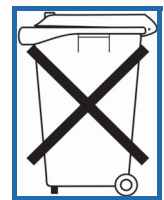

8.2 Correct disposal for reuse

The machine or piece of equipment is to be presented to a disposal station or, in case of replacement, to the supplier of the replacement machine or piece of equipment.

For more information, please contact the local agency responsible for the collection of waste and the like, or the municipal waste depot.



The owner of the machine or piece of equipment is responsible for the correct disposal of the machine.

Appendix 1

Technical information

A1.1 Dimensional drawing

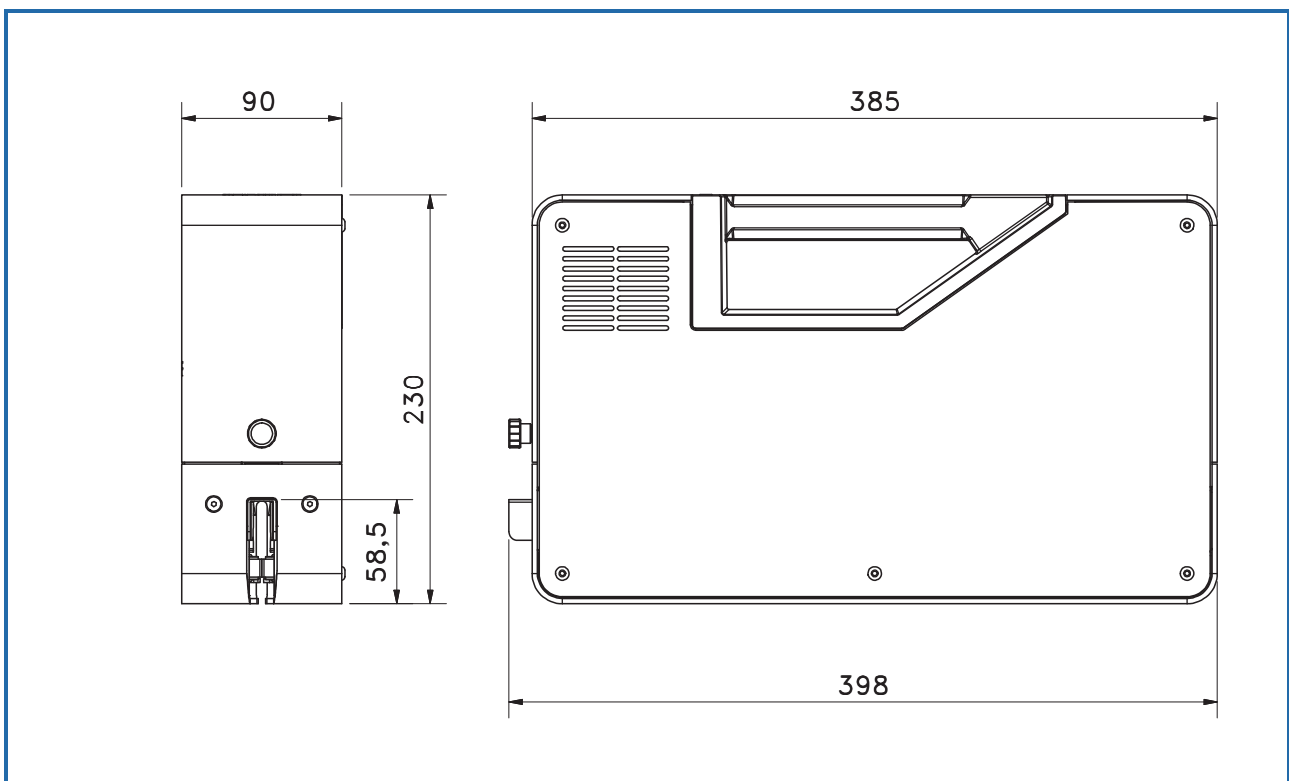

Figure 8-1: Dimensional drawing

A1.2 Technical information

General	
Dimensions	See the dimensional drawing
Weight	5.7 kg
Ambient temperature	+ 5 °C - + 40 °C
Humidity	30% - 95% rel. without condensation
Seal length	Unlimited
Seal width	4 mm
Sealing speed	Max. 5 metres per minute
IP value	IP31
Electricity	
Voltage	230 V - 16 A
Frequency	50-60 Hz
Earthing	Rim earthing
Power	400 W
Deviation from mains power system	< 10%
Fuse	4 AT
Length of power cord	± 1.8 m
Film	
Min. film thickness	PE film 2x20 µm PP film 2x20 µm Aluminium laminate 2x20 µm
Max. film thickness	PE film 2x120 µm PP film 2x120 µm Aluminium laminate 2x125 µm
Film insert	Min. 9 mm / max. 36 mm.
Max. film width	Unlimited

Bag dimensions	
Max. (bearing) weight	150 g.
Max. bag length	Unlimited
Max. volume	Unlimited
Emission	
Noise	< 85 dB(A)
Hand/arm vibration	< 2.5 m/s ²

Appendix 2

Electrical Diagram



Maintenance to the electrical installation should only be performed by authorised maintenance personnel.



Always remove the plug from the socket before carrying out maintenance work on the electrical installation.

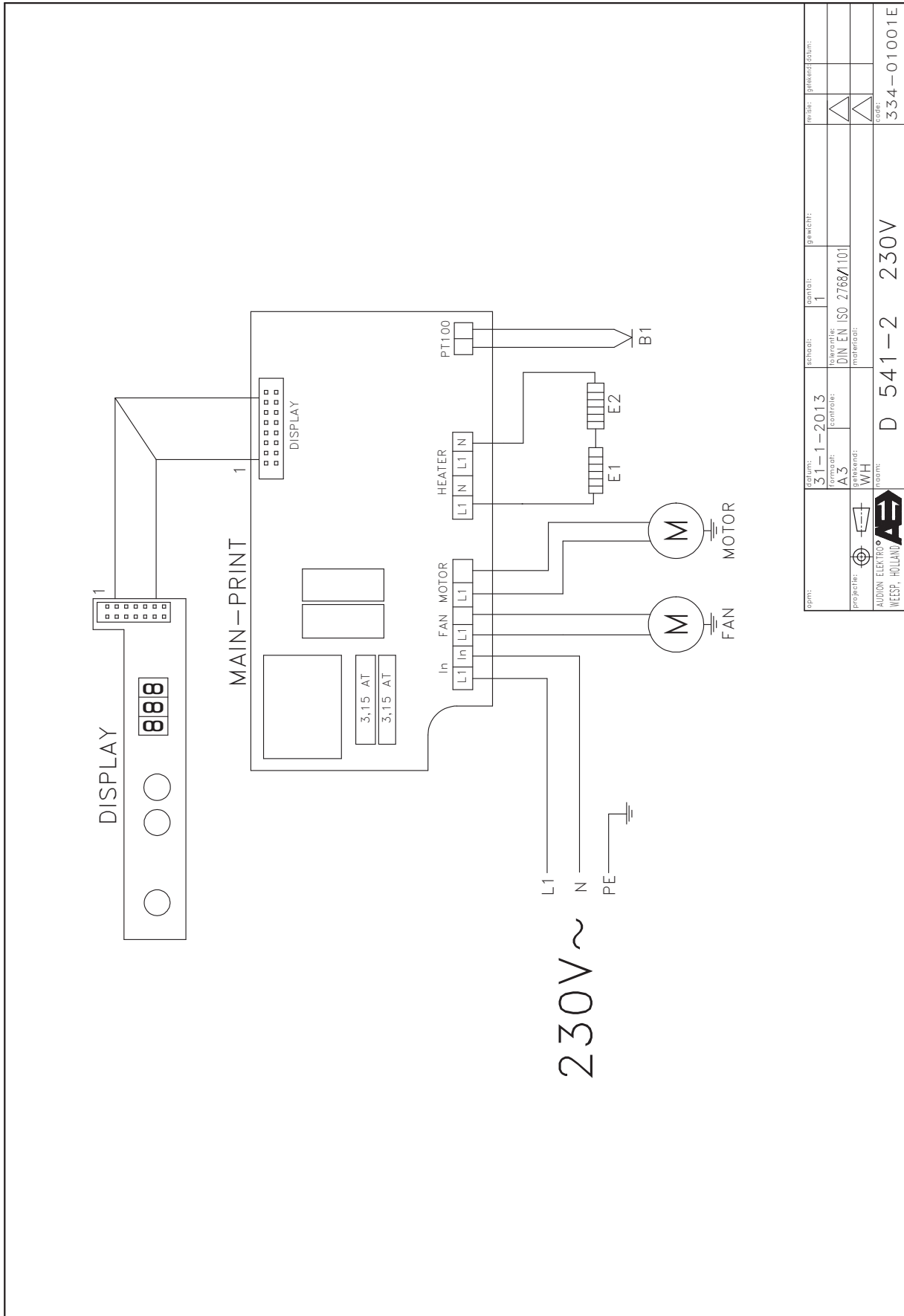

year:	31-1-2013	sheet:	1	weight:	
revision:	A3	to comply:	DIN EN ISO 2768M101		
project:	WH	drawn:			
part:	D 541-2	voltage:	230V		
part:		code:	334-01001E		

This publication, or parts thereof, may not be reproduced in any form, by any method, for any purpose.

Appendix 3

Spare parts



Only use original Audion parts for repairs and maintenance.



Repairs and maintenance should only be performed by authorised maintenance personnel.



Always keep a set of recommended wear parts in stock so that a defective part can be replaced quickly and the production process resumed without delay.

A3.1 Wear parts

Part	Qty per sealer	Item number
PTFE glass-fibre strip 541 660*8*0.14 mm	1	6119060
Glass fuse 3.15 AT	2	052032

A3.2 Service parts

Part	Qty per sealer	Item number
Feed-through tulle	2	009018
Bearing 626 ZZ for SPK 230	4	041611
Power cord 3*0.75 VMVL	1	054008
Device input for individual sale	1	054326
Blower 230V	1	131-00306
Ceramic element with sensor D541	1	280-02049-90
Ceramic element D541	1	280-02049-91
Insulating block D541	4	280-02052
Back plate D541 OPB = PC	1	334-00001
Cooling plate D541	2	334-00006
Tensioning spindle D541	2	334-00012
Lock ring D541	2	334-00017
Gear wheel D541 plastic	2	334-00019
Bevel gear wheel D541 plastic	1	334-00020
Bevel gear wheel D541 steel	1	334-00021
Front plate	1	334-00023
Guide pin D541	2	334-00031
Frame operating print D541	1	334-00148
Compression spring D541	2	334-00411
Bearing CS200LLU D541	2	334-00413
O ring D541	4	334-00414
Main print D541	1	334-05400
Operating print D541	1	334-05402
Electric motor D541 230V	1	334-05403
Sticker operating print D541	1	334-05407
Flat cable D541	1	334-05410
PTFE glass-fibre strip 541 660*8*0.14 mm	2	6119060

A3.3 Exploded view

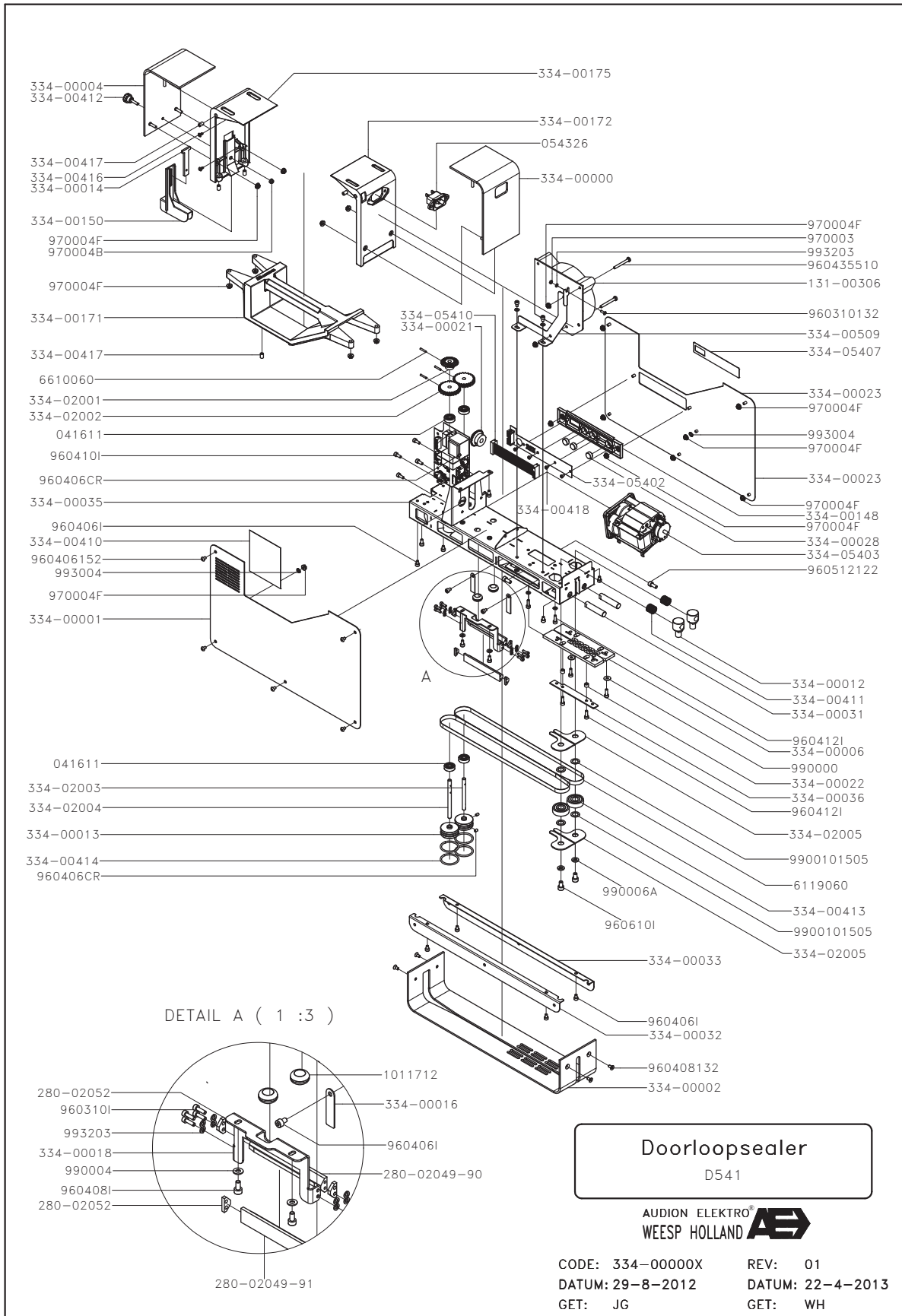

Appendix 4

Log



Always keep a log of all maintenance work.



See Chapter 7 - 'Maintenance' for an overview of the maintenance work to be carried out.



Make a copy of the log and use it to sign off the maintenance work.

A4.1 Maintenance log

Maintenance*	Remarks/parts replaced	Date	Performed by	Initials
Weekly/ Monthly				
Weekly/ Monthly				
Weekly/ Monthly				
Weekly/ Monthly				
Weekly/ Monthly				
Weekly/ Monthly				
Weekly/ Monthly				
Weekly/ Monthly				
Weekly/ Monthly				
Weekly/ Monthly				
Weekly/ Monthly				
Weekly/ Monthly				
Weekly/ Monthly				
Weekly/ Monthly				
*Strike out what is not applicable.				

Appendix 5

EC declaration

EC-DECLARATION OF CONFORMITY

AUDION ELEKTRO B.V., located at the Hogeweyselaan 235 in
Weesp, The Netherlands

herewith declares that the

EONTINUOUS SEALEE

Type:

D 541-E

- is in conformity with the provisions of the following EEC directives:
2006/42/EC Machine Directive ; 2014/30/EU EMC-Directive ;

- and that the following (parts/clauses of) harmonized standards have been
applied:

EN-ISO 12100; EN-IEC 60204-1;

Weesp, 29-5-2017

E.Tangelder

Director



PGR334A

Audion Elektro BV
Hogeweyselaan 235
1382 JL Weesp
The Netherlands
Tel + 31 (0)294 491717
Fax + 31 (0)294 491761
Email holland@audion.nl
www.audion.com

Represented by: